

1 Figure 1 shows the output from the terminals of a power supply labelled d.c. (direct current).

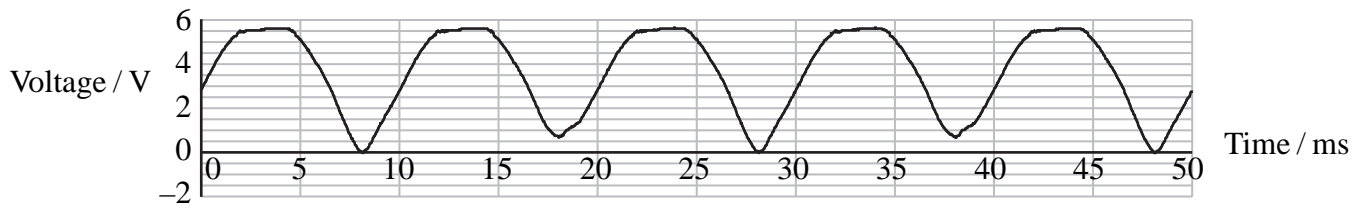

Figure 1

(a) An alternating current power supply provides a current that keeps switching direction.

Explain why the output shown in Figure 1 is consistent with the d.c. label.

(2)

(b) A teacher suggests that certain electronic circuits require a constant voltage supply to operate correctly.

(i) A student places a capacitor across the terminals of this power supply. Suggest how this produces a constant voltage.

(2)

- (ii) She uses a $10\ \mu\text{F}$ capacitor. Calculate the maximum energy stored in the capacitor.

(3)

Maximum Energy =

- (c) She now adds an electronic circuit to the power supply plus capacitor. Figure 2 shows the supply to the electronic circuit. This is shown in Figure 2.

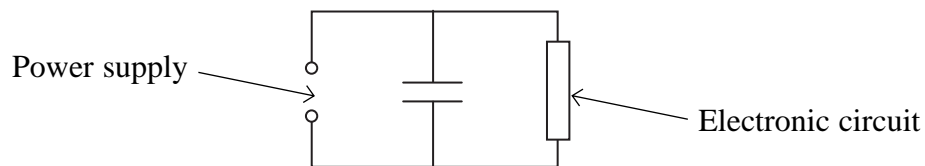

Figure 2

The variation in potential difference is shown by the graph in Figure 3.

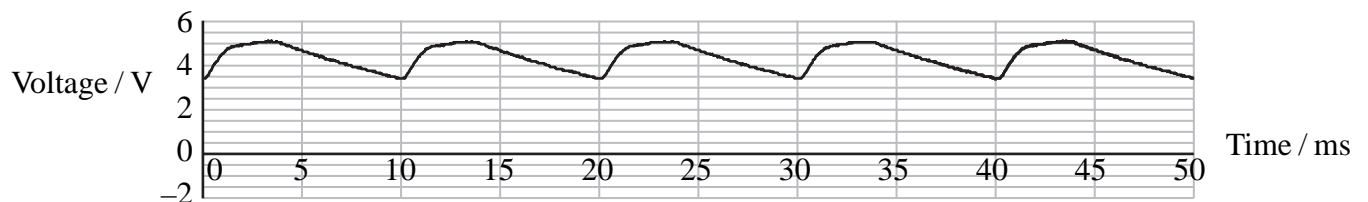

Figure 3

- (i) Explain the shape of this gra

(3)

(ii) Take readings from the graph to show that the resistance of the electronic circuit is in the range 1000Ω to 2000Ω .

(3)

(iii) Figure 3 shows that the voltage supplied to the electronic circuit still varies. How could the student make it more constant?

(1)

(Total for Question = 14 marks)

- 2 A defibrillator is a machine that is used to correct an irregular heartbeat or to start the heart of someone who is in cardiac arrest.



The defibrillator passes a large current through the heart for a short time.

The machine includes a high voltage supply which is used to charge a capacitor. Two defibrillation 'paddles' are placed on the chest of the patient and the capacitor is discharged through the patient.

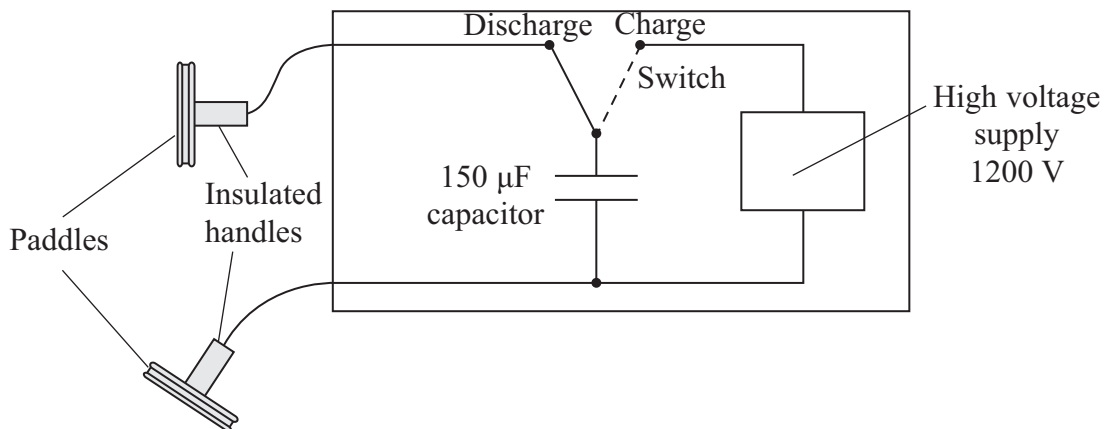

- (a) The $150 \mu\text{F}$ capacitor is first connected across the 1200 V supply.

Calculate the charge on the capacitor.

(2)

Charge

(b) Calculate the energy stored in the capacitor.

(2)

.....
.....
.....

Energy stored

(c) When the capacitor discharges there is an initial current of 14 A in the chest of the patient.

(i) Show that the electrical resistance of the body tissue between the paddles is about 90Ω .

(1)

.....
.....

(ii) Calculate the time it will take for three quarters of the charge on the capacitor to discharge through the patient.

(3)

.....
.....
.....
.....
.....

Time

(iii) Body resistance varies from person to person. If the body resistance was lower, the initial current would be greater.

State how this lower body resistance affects the charge passed through the body from the defibrillator.

(1)

.....
.....

(Total for Question 9 marks)

3 The diagram shows a circuit that includes a capacitor.

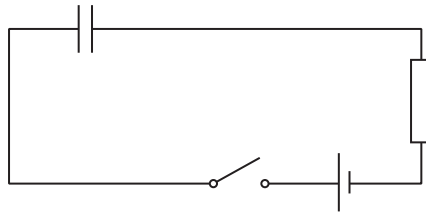

(a) (i) Explain what happens to the capacitor when the switch is closed.

(2)

.....

.....

.....

.....

(ii) The potential difference (p.d.) across the resistor rises to a maximum as the switch is closed.

Explain why this p.d. subsequently decreases to zero.

(2)

.....

.....

.....

.....

*(b) One type of microphone uses a capacitor. The capacitor consists of a flexible front plate (diaphragm) and a fixed back plate. The output signal is the potential difference across the resistor.

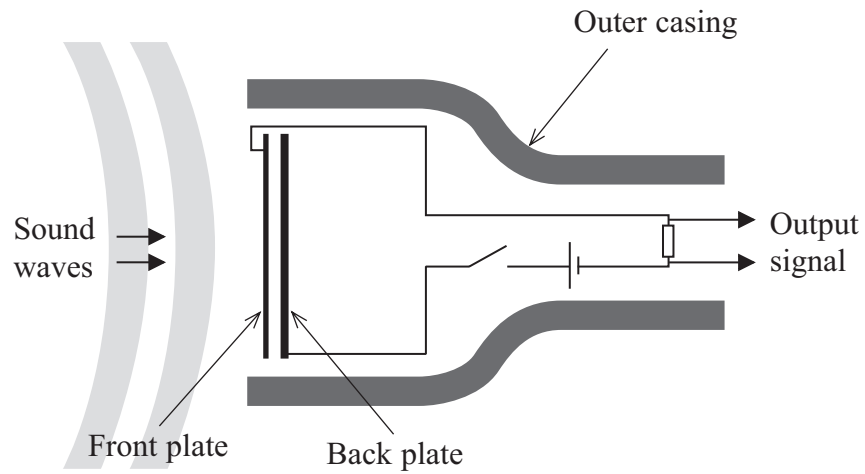

The sound waves cause the flexible front plate to vibrate and change the capacitance. Moving the plates closer together increases the capacitance. Moving the plates further apart decreases the capacitance.

Explain how the sound wave produces an alternating output signal.

(4)

.....

.....

.....

.....

.....

.....

.....

.....

.....

.....

.....

.....

.....

.....

.....

.....

.....

.....

.....

.....

.....

.....

4 A student sets up the circuit shown in the diagram.

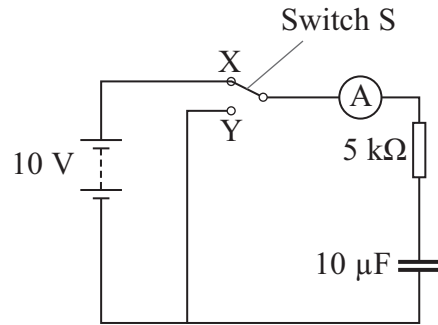

(a) (i) She moves switch S from X to Y. Explain what happens to the capacitor.

(2)

.....

.....

.....

(ii) On the axis below, sketch a graph to show how the current in the ammeter varies with time from the moment the switch touches Y. Indicate typical values of current and time on the axes of your graph.

(3)



(iii) Describe how the graph would appear when the switch is moved back to X. (2)

.....

.....

.....

(b) Calculate the maximum energy stored on the capacitor in this circuit. (2)

.....

.....

.....

Maximum energy

(c) The student wants to use this circuit to produce a short time delay, equal to the time it takes for the potential difference across the capacitor to fall to 0.07 of its maximum value.

Calculate this time delay. (2)

.....

.....

.....

.....

.....

Time delay

(Total for Question 11 marks)